

BUCHER
municipal

Bucher **MaxPowa V series**

V50, V65, V80





Extraordinary

results from our highly regarded sweepers

The MaxPowa V series has established itself as our most reliable and dependable truck mounted sweeper. Our latest sweepers have been developed from over 60 years of evolution and continuous improvement to meet the requirements of our customers.

With tailored machines in your chosen field, Bucher Municipal offer a wide choice of products and options, which ensures maximum performance is always achieved.

The MaxPowa V series truck mounted road sweeper has been developed to provide longer on-station time with the lowest environmental impact, combined with ease of use and low operational costs.

The MaxPowa V series excels in each of these areas; high performance, high productivity, lower cost of ownership, environmental impact, safety and operator experience.



High **performance**

The MaxPowa V series is supplied with a choice of three hopper capacities and a range of power packs to tailor the sweeper to the operation. A wide range of options extends the functionality further to provide a truly versatile machine.

Maximising on-station time requires a balance of having enough water capacity to minimise refills, having enough hopper capacity to cope with large volumes of leaves or debris, having a payload great enough to meet the demands of a workday and being able to carry enough fuel to reduce non-productive travel.

Over years of development, Bucher Municipal feel we have achieved a near perfect balance of the requirements to provide possibly the best performance road sweeper.



Up to 7000 kg payload
With an 18000 kg GVM.

Up to 3600 mm
Up to 3600 mm swept brush width on simultaneous sweep (with an optional side slide brush increasing swept brush width to 4200 mm).

Up to 4000 litres
Standard water capacities from 1330 litres on the MaxPowa V50, 1545 litres on the MaxPowa V65 to 2300 litres on the MaxPowa V80. Additional options vary from 700 to 1700 litres (depending on option compatibility).



V50t/V65t/V80t Auxiliary Engine

A twin engine sweeper provides the greatest flexibility. The sweeping operations are totally independent from the chassis and therefore can offer the lowest fuel consumption on low revs or best possible suction performance on maximum revs. The auxiliary engine can be fuelled by tax free diesel where permitted, allowing significant cost savings.

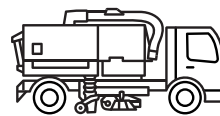

V50h/V65h/V80h Hydrostatic Drive

The patented hydrostatic gearbox can work with large chassis engines up to 280 hp. In hydrostatic drive, the sweeper offers infinitely variable speed control and can transit up to 40 kph. It can also be supplied with cruise control.



V50m/V65m/V80m PTO Drive

An engine PTO (power take off) can be used to drive all the sweeping functions. Due to the minimum PTO torque required, the Vm is limited to a selection of chassis brands.



Smoothflow

The cowl provides a noise suppressing and weather proof enclosure for the powapack. The unique Smoothflow air system has been designed to maximise airflow providing over 40% better suction performance over previous models.



5, 6.5 or 8 m³

5 m³, 6.5 m³ or 8 m³ hopper options.



175-190 litre fuel tank

The V50t/V65t/V80t auxiliary engine uses from only 4 litres per hour making it an excellent choice.

High **productivity**

Productivity is driven by reliability and dependability through fewer breakdowns or service interventions. Combine this with great suction performance, quick engage options and an ease of onsite adjustments or consumable replacements and your time working increases.

The MaxPowa V series delivers great productivity with standard features and a wide range of options to match your operational needs.

650 mm or 500 mm channel brushes with an optional side slide brush arm for weed ripping or extended swept width.

Dual sweep can sweep both near side and offside kerbs and change from one to the other simply via a single button.

The Vt has a JCB 55 kW industrial engine, designed for operating in dusty environments. Providing 400 Nm of Torque at 1250 rpm the Stage 5 engine is ideally suited for road sweeping operations whilst offering low fuel consumption (EU27 only).

A JCB 97 kW engine is available offering a max torque of 550 Nm at 1500 rpm for applications where higher suction is required; for example more arduous road construction operations (EU27 only). An Optional JCB 85 kW 3a engine is available outside of the EU offering a max torque of 440 Nm at 1300 rpm.

Data-capture is standard via the JVM providing data on service information and the sweeper. Data can be downloaded via a USB stick and uploaded onto a spreadsheet showing engine revs, fuel consumption, sweeping time and if fitted with a tachograph, distance travelled and distance swept.

Variabrush allows the operator to maintain a safe and consistent distance from the pavement, by adjusting the channel brush position to follow the kerb line; enhancing the functionality of the sweeper.

* Optional equipment



500 hours between routine services on JCB engines.

Shortest wheelbases designed with major chassis manufacturers to improve turning circles.



Top mounted wanderhose*

The top mounted wanderhose with 280 degree rotation, available in a 150 mm or 200 mm diameter with water injection, can be used to empty gullies down to 1570 mm safely from the kerb side.



Simultaneous sweep*

Simultaneous sweep allows both brushes and vacuum nozzles to operate at the same time.



Rotatilt*

Rotatilt option adjusts the angle of the channel brush from the cab to clean crevasses and cambered roads.



Rear Suction nozzles*

Full width suction nozzles to the rear of the machine, in addition to mid-mounted nozzles for exceptional pick-up performance. Available with 22 V jets when selected in combination with the Powawash option, 120 l/min @ 160 bar (V80 only)



Supawash*

Provides an option for high pressure water, 30 l/min @ 100 bar to clean roads and kerb lines. The hand lance and 15 m hose reel can be used to clean street furniture and the machine itself.



Rear Mounted Wanderhose*

Heavy duty, rear mounted wanderhose is also available to allow gully emptying. The single piece rear hose provides fast deployment with a max cleaning depth of 1475 mm. *

Lower **Cost** of Ownership

Capital cost is only part of the operational expenditure of the sweeper. Fuel consumption, maintenance costs and resale values can outweigh the initial purchase price offering better value in the longer term.

The MaxPowa V series has been designed to last, perform at lower revs and have more durable wearing parts.

All models feature a 4 mm thick 1.4003 stainless steel hopper and integrated water tank. A 2 mm thick mild steel cowl is standard with optional 1.4003 stainless steel upgrade. Stainless steel mesh screens are also available if required.

The powder painted process starts with shot blasting components prior to the application of zirconium based pre-treatment to create a clean and adhesive surface for a satin primer. The resulting powder coat layer creates a highly effective barrier against corrosion increasing durability of the sweepgear.

* Optional equipment

The rear door features heavy duty stiffeners and the rear chute is made from stainless steel for extended durability.

Corten inlet tubes and seats reduce wear even in the harshest of environments.

Bolted replaceable rubber seals and quick change brushes reduce downtime for consumable replacements.

As standard, the MaxPowa V series sweeper features a Pressadrain water purging system so that when freezing weather conditions are anticipated, water is easily and conveniently drained from the sweeper.

Water jets in the nozzle boxes are self-cleaning which extends the life of the components.



JVM screen

JVM system with 7" colour screen provides fault diagnosis and operational feedback for the sweeper including engine codes.

Systems locker

The electronic nodes, hydraulic adjustments and pneumatic systems are centralised in the systems locker complete with convenient LED strip light, making repairs and fault finding easier and faster.

Kick back feature

Trailing brush arms have a kickback function as standard protecting both the sweeper and street furniture.

Supawash Hose*

The Supawash hose has a short lead with a connector attached to the 15 metre hose. This allows the full length hose to be replaced quickly in the event of damage.



Door locking mechanism
Heavy duty twin locking mechanism with minimal proximity switches, to ensure a tight seal and prevention of leakage.



Combi cooler radiator
Single triple stack cooling pack for improved cooling performance and ease of cleaning.

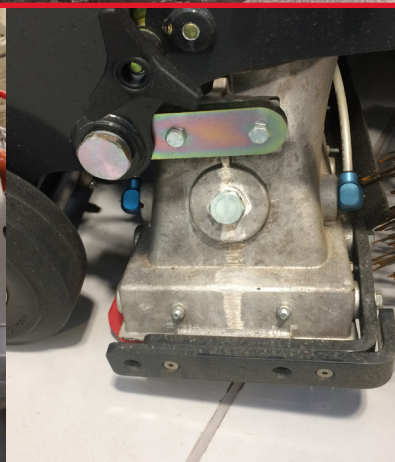

Heavy duty nozzle*
Optional heavy duty nozzle box wheels and bumpers reduce damage and extend wheel life.



Easiclean*
Easiclean option can connect to a hydrant to flush the inside of the hopper, cleaning the roof duct and behind the inlet tubes.

Low Environmental Impact

Road sweepers are the only vehicles on the road that reduce harmful emissions by trapping particulate matter collected from the road surface in the hopper. The MaxPowa V series does this with the lowest environmental impact Bucher Municipal can design.

Low noise

All sweepers are equipped with noise suppression hoods, encapsulating the auxiliary engine and fan casing and noise attenuation vanes are installed as standard in the air exhaust system. Noise at the driver's ear is less than 75 dB(A) at maximum revs (chassis dependant), creating a safer operating environment for both the driver and pedestrians. The engine can be set to lower revs for night sweeping which reduces the noise levels by 50%.

High dust suppression

Debris is sucked in a direct route from the vacuum nozzle into the hopper, reducing wear and tear as well as maintenance. Once debris is in the hopper, the cyclonic airflow helps separate debris, and the clean air is released into the atmosphere.

Low fuel consumption

The twin engine sweeper uses less fuel at lower revs than the single engine sweepers in the majority of applications. The twin engine has three power pack options to allow the best balance of fuel consumption, cost and power to match the application.

Low water usage

The MaxPowa V series uses as standard yellow mist atomising jets to reduce water usage by 20% or red nozzle jets, with higher flow are available for heavier applications. The optional Water Recirculation System can save up to 900 litres of water per day extending the on-station time and reducing the risk of dust going through the fan.

HVO compatible

All JCB auxiliary engines are HVO (Hydrotreated Vegetable Oil) compliant. HVO has the equivalent productive output as diesel but burns cleaner and with significantly lower damaging emissions up to 90% less Carbon Dioxide (CO₂) and 30-70% less NOX (nitrogen oxides). A non fossil fuel, HVO can be used 100% or with any EN590 diesel mix without modification or change in servicing requirements.

CNG compatible

The hydrostatic drive can be installed on an suitable CNG sweeper packed chassis, offering the same compact wheelbase as the diesel version.

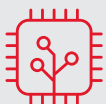

EUnited 4* Certified Smoothflow Air System

Re-designed airflow system to maximise air delivery and minimise losses, improving suction performance whilst reducing fuel consumption and noise.



Safety

Safety is everyone's responsibility and Bucher Municipal has considered all areas of human interaction when designing the MaxPowa V series sweepers.

Automatic body prop

A highly visible, self-engaging body prop provides the operator and service personnel with a safe working environment. As it is disengaged from the radio controlled remote pendant, there is no need for anyone to work under an unsecured body.

Radio Controlled Pendant

The radio controlled remote pendant allows the operator to walk completely around the sweeper without having wires to contend with. The operator can adjust the wide sweep brush easily and can check the surroundings before opening the hopper or tipping.

Lighting

The MaxPowa V series can be supplied with a wide range of optional LED work + hazard lights to make sweeping safer and easier.

Improved direct vision

The V series now comes with an adjustable JVM screen. This allows the operator to adjust the JVM screen and control box to suit their driving position.

An updated door controller keypad with improved information and LED lights indicate which sweeping functions are on so the operator reduces the number of times they have to look away from the road.

The JVM screen provides information on the sweeper's performance and doubles up as the camera screen, reducing the requirement for additional screens in the cab.

Engine bay access

The engine bay access is via a wide folding ladder with three points of contact. Hand rails provide safer access and regress in the engine bay area. The hydraulic tank provides a wider platform for the operator to stand on whilst carrying out minor inspections and checks.



Offside camera

Offside road view, providing additional vision for potential blind spot.



Handwash*

An electric hand wash option with removable bowl can be fitted to provide heated water for washing.



Hi-vis brush plates

High visibility brush plates and hose sleeves makes it easier for the operator to see the brush position and alerts pedestrians, cyclists and other vehicles to the position of the brushes.



Radio controlled pendant

Wireless pendant for hopper opening and tipping and wide sweep brush adjustments.



Sweepgear worklights

Optional Double or Triple sweepgear worklights illuminate the side of the sweeper and kerb



Beacons

Optional LED cab roof bar beacons

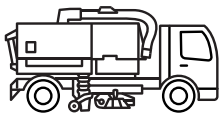

Rear worklights

Optional Rear mounted worklights offer an illuminated area behind the sweeper for reversing and working



LED flashers

Optional 4 LED flashers mounted on the rear door



Reversing lights

Optional Rear mounted work/reversing lights can provide other site traffic with a highly visual reverse indicator which can be set to flash when reversing for added safety.



LED light board

Optional LED light board with programmable messaging



High Tipping Angle Door

And sloping hopper floor for ease of discharge.



LP13 Signboard

An LED LP13 Signboard can be installed for highways contracts.

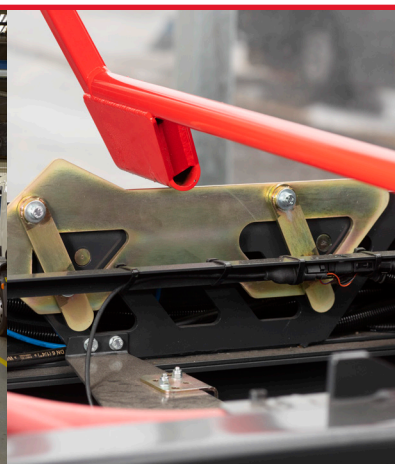

Body Prop

Highly visible self-engaging body prop

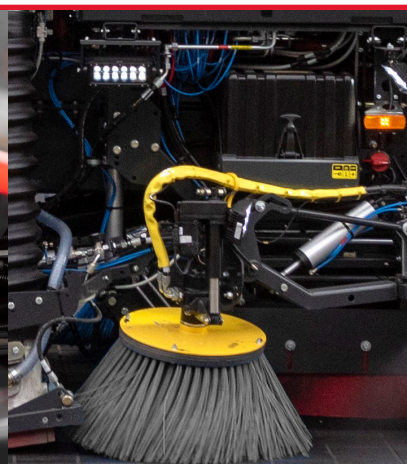

Triple Work Light*

Double or triple sweep gear work lights illuminate the side of the sweeper and kerb or the road planing kit. *

Operator **Experience**

The MaxPowa V series sweeper has been cleverly thought through with the operator in mind. Ease of use, great suction performance, minimal effort required to set-up, clean and operate, often makes the V series the operators' first choice sweeper.

JVM display

Daily checks are carried out via the JVM and auto-updates for the life of the sweeper. The centre console can be adjusted to suit the operator's preferred position.

The JVM has a wide range of settings that can be tailored to suit the operational needs including optional Preference Plus for a range of additional settings to customise your sweepers functionality. Features available include a boost setting for Ecomode or pausing of the sweepgear when overloaded or on low fluid levels.

Door Controller

A heavy duty pause button allows the operator to lift all the sweep gear and put the engine in tick over until depressed again. This allows the operator to change from sweeping to transit in a quick and easy way, and easily back again to sweeping. The MaxPowa V series remembers the last sweeping settings used each time.

Side Door Lockers

The MaxPowa V series has two lockable large side lockers for storing equipment including wanderhose extensions and standpipes.

Cleaning

The MaxPowa V series features a sloping hopper floor; this allows leaves and debris to slide out of the hopper easily, reducing the amount of cleaning required. An optional Easiclean system which flushes the air duct and behind the inlet tubes.



Easiadjust Nozzle

Simple adjustment of the nozzle for reduced set up time.

Mesh retention hooks

The mesh screens are released and locked from the retaining clips via the door opening mechanism reducing the effort required to open and clean.

Door controller

The ergonomic door controller can be used for all the sweeping operations, brush position, pressure, speed, nozzle aperture, engine revs and water jets.

USB charging points

A centre console, featuring cup holders and USB charging points, can be adjusted to suit the operator's preferred position.



Bucher Municipal Ltd

Curtis Road
Dorking, Surrey
RH4 1XF
tel. +44 (0) 1306 884 722
fax. +44 (0) 1306 884151

www.buchermunicipal.com

At Bucher Municipal, we innovate and engineer better cleaning and clearing solutions, helping our customers grow and maintain efficient and profitable businesses. Leveraging the over 200-year-old heritage of Bucher, we are committed to helping you achieve more using less. Taking pride in being seen as a reliable partner, we work locally with you in realising the possibilities for a smarter, cleaner and more efficient tomorrow. Today.



● Bucher Municipal locations
● Distribution Partners

Driven by better

Bucher MaxPowa V80

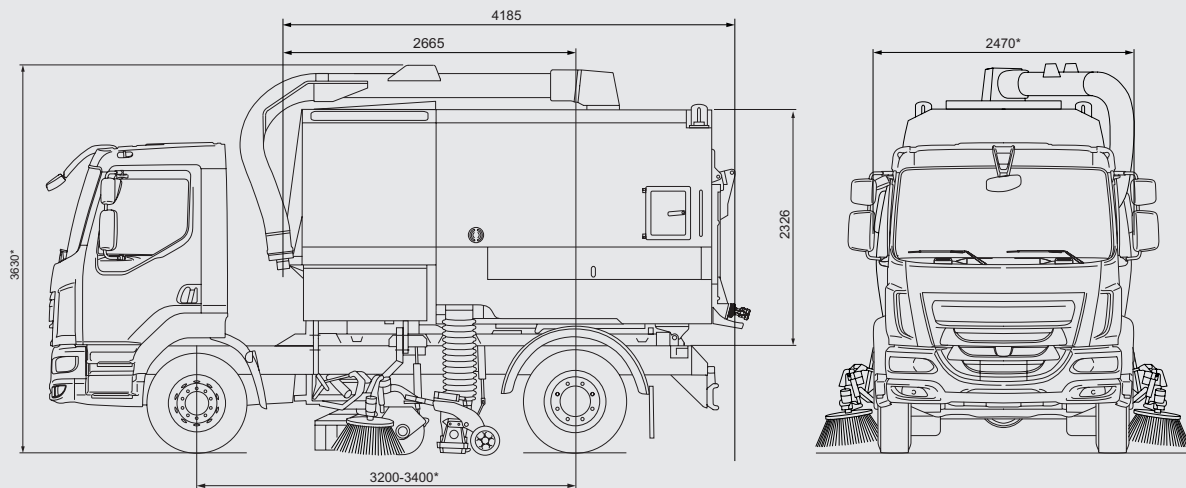

Dimensions

Length (cowl and hopper)	4185 mm
Width*	2470 mm
Height*	3630 mm
Wheelbase*	3200-3400 mm nominal
Sweeping path of suction nozzle and channel brush	1300 mm
Sweeping path with roller brush	2400 mm
Sweeping path for double-sided pick up	3600 mm

Noise level cab

<75 dB(A) generally
(dependent on chassis selection)

Alternative drives

Semi-hydrostatic	V80m
Hydrostatic	V80h

Chassis

GVM	15 - 18 tonnes
-----	----------------

Diesel fuel tank

Capacity	(up to 190 l with Stage 3a) 170 l
----------	-----------------------------------

Auxiliary engine

	V80t
Standard:	JCB Dieselmex 448 NRMM Stage 5
Gross power	97 kW @ 2200 rpm
Max torque	550 Nm @ 1500 rpm
Option:	JCB Dieselmex 444 NRMM Stage 3a**
Gross power	85 kW @ 2200 rpm
Max torque	440 Nm @ 1300 rpm

* Dependent on chassis and/or option selected
** Not for EU, 24v only

Features



Quad Camera

for off-side road view providing additional vision for potential blind spots.



HMI Centre console

featuring cup holders and USB charging points can be adjusted to suit the operators preferred position.



Body prop

highly visible and self-engaging provides the operator and service personnel with a safe working environment.

Bucher MaxPowa V80

Controls

Centre cab mounted master control panel with JVM providing information on a wide range of sweeper functions plus data capture download. Up to four optional cameras can also be viewed on the JVM screen. Separate palm rest controller housing controls for the main sweeping functions is mounted on the door side.

Exhauster fan

Operational speed variable between 1800 rpm - 3500 rpm to suit operation. V80t: Step-up gearbox ratio: 1.79:1

Channel brush

Quick release brush system with infinitely variable speed up to 160 rpm (cab controlled). Hi-visibility yellow brush plate and hose guide.

Nozzle

Cast aluminium nozzle with 250 mm diameter inlet and tool free adjustment.

Dust suppression system

Dust suppression sprays located at suction nozzle(s), channel brush(es) and across front of vehicle. Pressadrain water purging system. EU certified PM10 4* Certified.

Electrical system

24 volt. All external loom connections are full automotive IP67 rated.

Exterior noise / Sound power level

LWA 112 dB(A) for high power engines measured in accordance with EC directive 2000/14/EC.

Hopper

Body comprises of hopper & integral water tank. Fabricated from heavy duty stainless steel plate. Water tight twin lock rear door latching system with de-watering function. Two body side access doors and side storage lockers.

Plug in hopper floor as transfer port for use as Streetwasher. Rear discharge chute, automatic multi position body prop, twin caged rear beacons and LED worklights are standard features.

Hopper voided volume ***	8.0 m ³
Discharge angle	56° nominal
Door opening angle	125° nominal

Water tank

Water tank incorporates anti-surge baffles and filled via a type 'A' water hydrant fill. A twin diaphragm pump runs continuously and is able to run dry. Water capacity 2300 l

Cowl

Smoothflow cowl lined with frequency matched soundproofing material.

Brushes

Wide sweep brush	Ø 406 mm
Width of wide sweep brush	1275 mm
Width of suction nozzle	750 mm
Channel brush	650 mm

Options

- Camera monitoring systems.
- Powathrust/Powasave.
- Pneumatic mesh shakers.
- Powascrub - wide sweep brush ground pressure device.
- Supawash: high pressure washing system, 32 l/min @ 100 bar.
- 6" or 8" boom mounted Wanderhose with power assist option.
- Side Slide Brush
- Triple Sweepgear Worklights
- Bonded Intake Ducts

*** All Bucher Municipal Hopper Capacities are measured in accordance with European Standard EN 15429

Bucher Municipal



For local contact and support, please scan the QR code or visit

buchermunicipal.com

Driven by better



Bucher Municipal E-Shop

Version 05_09/2021
Technical data is subject to change without prior notice.
The illustrations may deviate from standard equipment.